

- Aluminum Diaphragm
- NBR Rubber Surround
- Neodymium Motor
- Copper Cap
- Enhanced Voice Coil Cooling

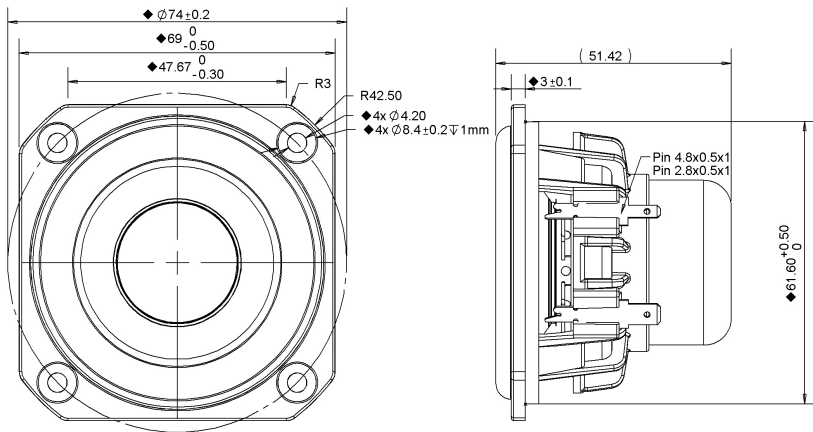

SPECIFICATIONS

Transducer Size	2.5	in	
Impedance	8	Ω	
Frequency Range ¹	80 - 16000	Hz	
Sensitivity ² (2.83V 1W @ 1m)	82.6 82.7	dB	
Power Rating (IEC 268-5)	25	W	
Voice Coil Size	25.7	mm	
Air Gap Winding Height	$H_{ag} H_{vc}$	4 8.1	mm
Net Weight	0.145	kg	

PARAMETERS ³

Eff. Piston Area	S_d	21.2	cm ²
DC Resistance	R_e	6.3	Ω
Minimum Impedance	Z_{min}	6.6	Ω
Inductance	L_e	0.101	mH
Resonance Frequency ⁴	F_s	110	Hz
Mechanical Q Factor	Q_{ms}	5.46	-
Electrical Q Factor	Q_{es}	0.87	-
Total Q Factor	Q_{ts}	0.75	-
Moving Mass	M_{ms}	2.27	g
Compliance	C_{ms}	860	$\mu\text{m}/\text{N}$
Equivalent Volume	V_{as}	0.547	L
Motor Force Factor	Bl	3.43	Tm
Motor Efficiency	β	1.87	(Bl) ² / R_e
Linear Excursion ⁵	X_{max}	3.38	mm
Max Mechanical Excursion ⁶	X_{mech}	-	mm

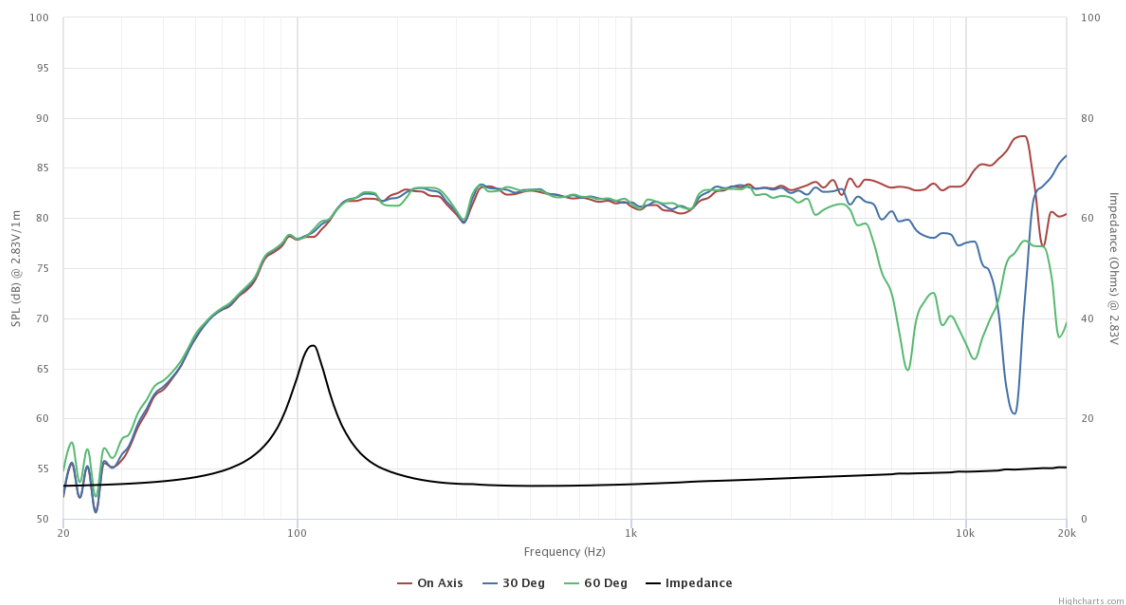

Details on this spec sheet are for reference only and should not be used for setting production limits. Specifications and product cosmetics are subject to change without notice. Peerless is a registered trademark of Tympany Enterprises. All measurements conducted in test lab at 25°C ±10°C, 50%RH ±10%. ¹ Specified by Engineering as linear working range of transducer. ² Measured at 2.83V at 1m and normalized to 1W with respect to nominal impedance. ³ Measured in Free Air without preconditioning, therefore subject to some deviation. ⁴ Impedance and F_s value measured under different conditions. ⁵ Equal/Overhung: $(H_{vc} - H_{ag})/2 + H_{ag}/3$. Underhung: $(H_{ag} - H_{vc})/2 + H_{vc}/3$. ⁶ Mechanically limited excursion (e.g. bottoming, spider crash).